

## Tips for Properly Maintaining Your Pizzi Glue System

### After Use:

After each gluing period, the gun with nozzle attached should be placed back in the water reservoir that is supplied with all 9001 and 9012 tanks. This will prevent the glue from drying in the nozzle and becoming hard to clean and remove, and it will ensure your glue flows smoothly and evenly.



*Place the nozzle in the water reservoir after use.*

### Daily Care:

All nozzles should be removed from the end of the Pizzi gun and cleaned in the sink using nozzle #0044, which is supplied with all new tanks or available for purchase. Using water, clean the gun and pay particular attention to the threaded area and brush nozzles, being sure to remove all glue.

Since Pizzi systems are pressurized gluing systems, having a maintenance plan which maintains your tanks and nozzles at regular intervals- after use, weekly, monthly, and yearly- is critical to the overall performance of the system. The Pizzi system requires very low maintenance. Performing basic clean-up and regular care will ensure your system's longevity and high performance.

---



The 0044 fits all nozzles and attaches to a faucet.



Take special care with brush nozzles.

Be sure to flush the gaps in the 0029 attachment.

## Weekly Care:

Check pressure levels of the Pizzi tank to ensure proper level. If the level becomes lower than 5 bars (75 psi), add compressed air, and monitor for leaks.

Check glue levels. A common reason for leaking is related to the rubber seal around the lid; part #10041 (for 9001) or #10153 (for 9012), highlighted in red in the diagram. Both rubber seal rings are regularly stocked items for purchase.

## Gaskets to Check

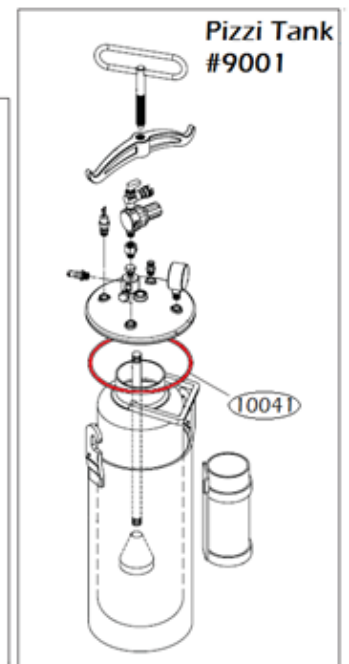
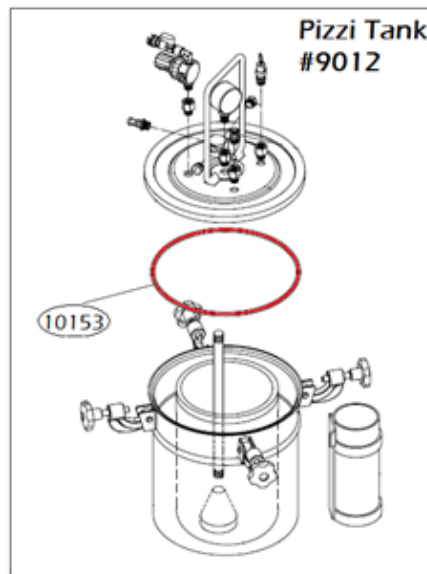



## Monthly Care:

Inspect Pizzi gun #0002 (standard) for leaking. The gun may develop some leakage due to normal usage deterioration of a small rubber ring (part #10020) over time. This rubber ring is recommended to be replaced once every year. Inspect and replace damaged nozzles if needed; open the gun by removing the pin from the trigger and unscrewing the interior components.

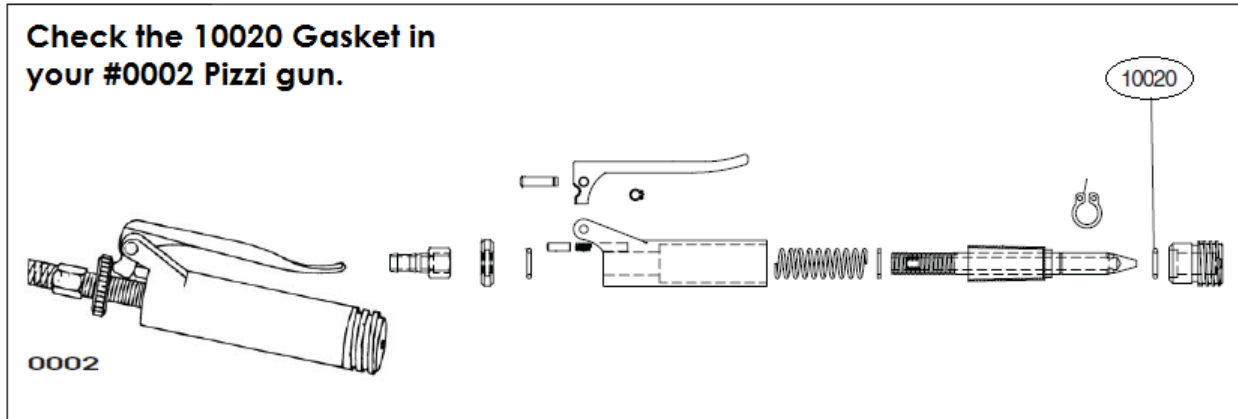

---

## Yearly Care:

Over time, nozzles begin to break down due to the nature of gluing operations. While the effective life of your attachments can be extended with proper care and maintenance, all attachments will eventually degrade with time and use. Some signs your attachment is wearing down and may require replacement include glue buildup on the glue gun around the threaded end, where the nozzle is attached, or cracks developing on the plastic housing of the glue gun. It's recommended to replace the tank lid rubber seal (#10041 for 9001 or #10153 for 9012) yearly.

### Check for cracks on the nozzle.

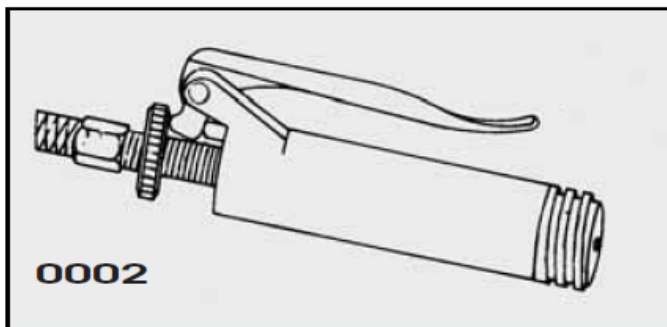

Inspect for glue buildup on the threaded end.



Check the 003 nozzle for normal wear and tear.

---

Rangate stocks one of the largest selection of Pizzi nozzles and glue guns in the world for immediate shipping. For information, consult the [catalogue of standard attachments](#) [PDF, 436kb] and [email us](#) on your need.

